



YOUR PATH TO SUCCESS

Introducing First Time Ever in India

# Track & Trace with END TO END AUTOMATION for Secondary Packaging Line

An Ultimate One in All Solution For Bottle Line

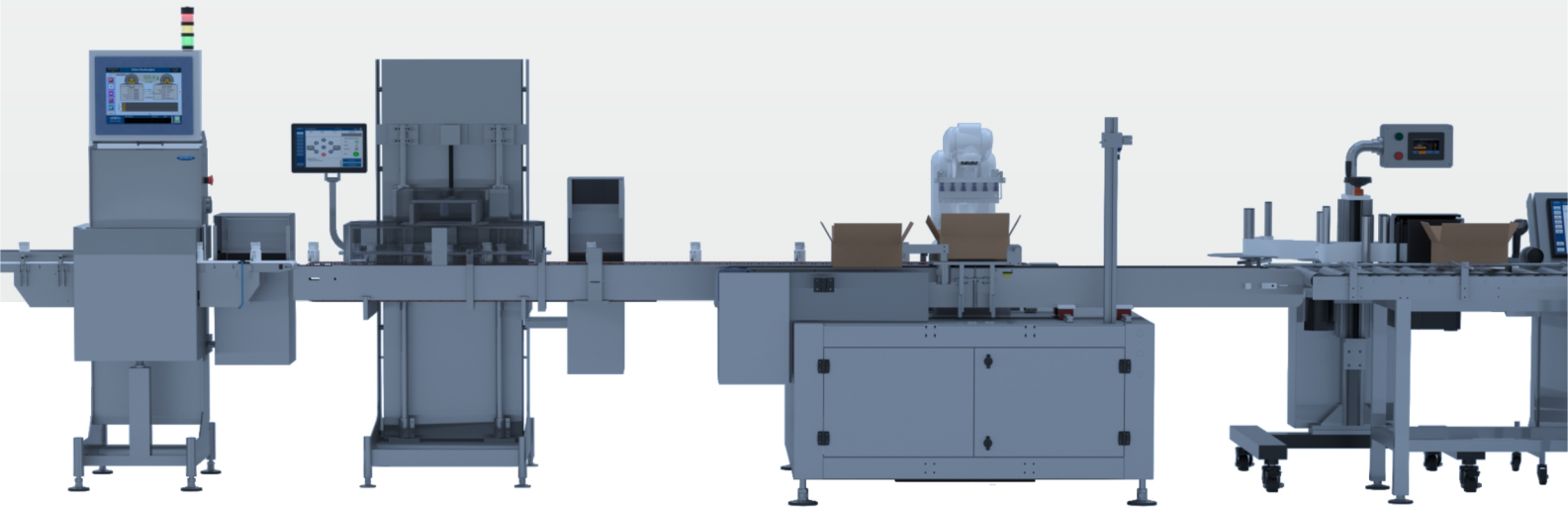

# Smart, Accurate and Secure Track & Trace Solution

Our turnkey serialization solution with a smart Track & Trace technology confirms the products across the supply chain. Here's the one of its kind packaging solution with zero human intervention process.

The latest End-to-End solution for US bulk packing secondary line provides all in one solution. It comprises Labeling machine, Topsert pasting machine, online check weigher, Smart 360° scanning system for code association, Robotic Pick & Place based Case Packer, Case erector, Case Sealer, Online case weighing, Track & Trace along with Print & Apply that will expedite and streamline your entire packaging process.

Our pro machine has an inbuilt high speed and high resolution camera with specially designed illumination technology that reads and confirms the serialization codes. This data is then captured and sent to the assigned server in order to verify the details.

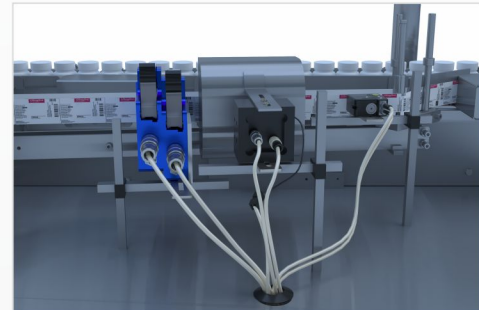

High speed Printer and Camera Inspection system

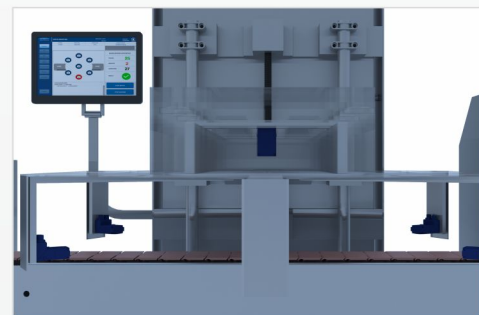

360° 2D Code Scanning System



ROBOTICS PICK & PLACE

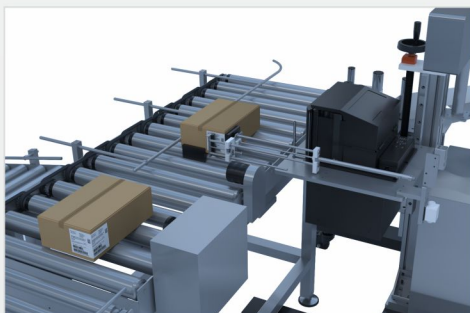

Online Print & Apply system

After the confirmation, Print & Apply mechanism prints a case label, and then the label is applied to the case. This aggregation creates a parent-child relationship to maintain proper hierarchy of products for a secure supply chain through Track & Trace system. At Shubham, we believe in offering solutions that adhere to 21 CFR PART 11 compliance to ensure the best product packing process in the industry.

Our advanced end of packaging line solutions are crafted specially for prominent Pharma companies. We produce high-quality packaging automation solutions customized as per your requirement so you can be flexible, adaptable, consistent and as fast as you need to be.

# End to End Bottle line solution

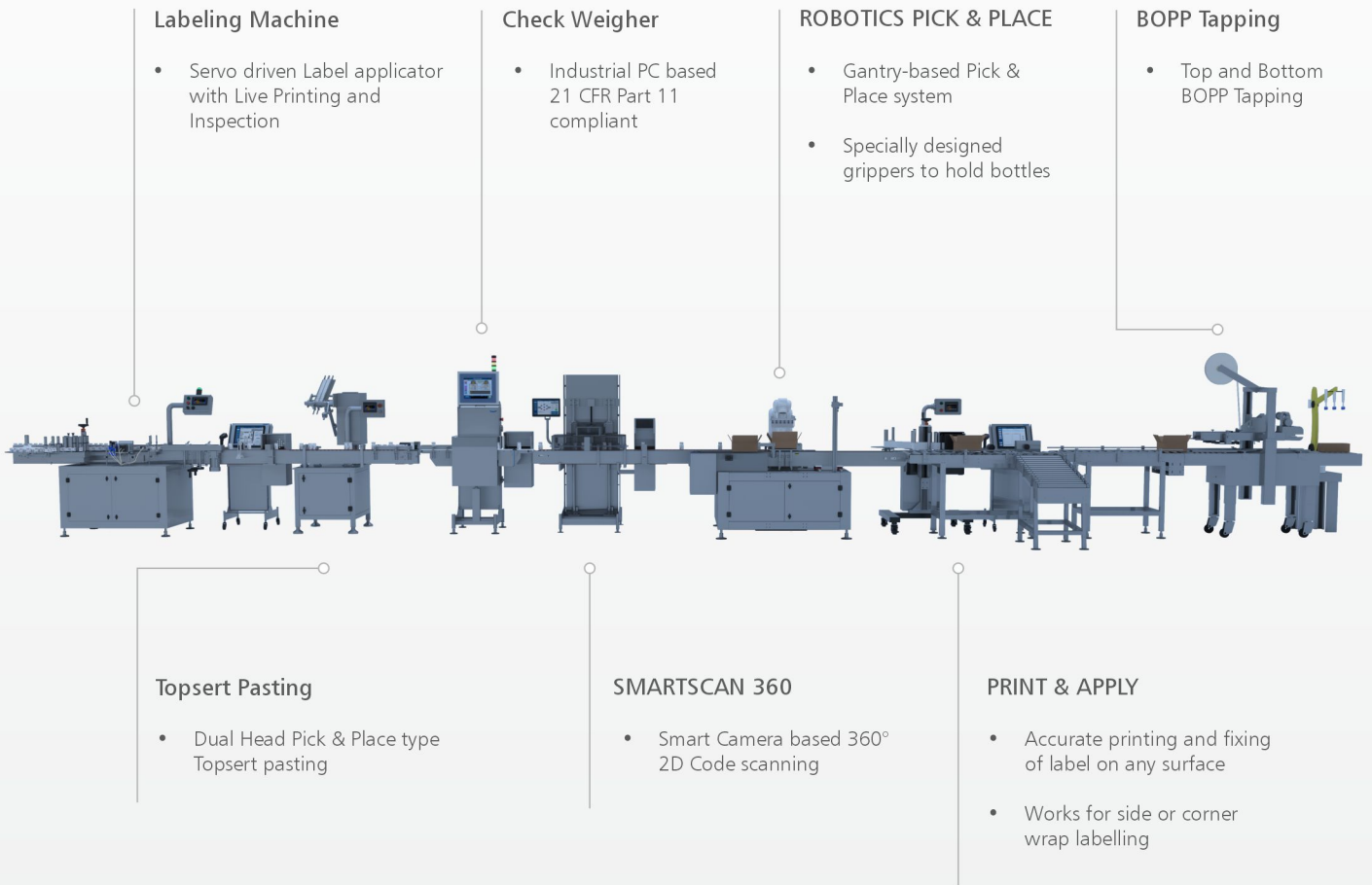

## Key Benefits



### QUALITY CONTROL

All required government approved compliant measures are taken to ensure the quality is intact.



### ONE STOP SOLUTION FOR TRACK & TRACE

From serialization to aggregation, this is the ultimate solution for your end of packing line.



### EASE OF OPERATION

This all in one solution will surely make your life easier by smoothening the packing operations.



### IMPROVED PRODUCTION SPEED

Automation accuracy and operations amplifies your production speed to the next level.



### BETTER INFORMATION ACCESS

Get all the required packing data organised under one platform.



### REDUCED LABOR INJURIES

With zero manual intervention, there's hardly a chance of labor injury.



### REDUCED STAFF HOURS

Our solutions are versatile as it provides fully automatic with cutting-edge technology and innovative products.

# Industry Pains due to human intervenes



Still depend on **manual inspection for quality assurance** at each packaging stage?



Do you experience **slow operational speed** during the packing process?



Do you face **data integrity in your serialization** process?



Incurred a **huge loss due to product damage** of a product?



Have caused frequent **workplace accidents** and labor risks?

## We Are Trusted Worldwide

Delivering world class Industrial Automation solutions for more than 2 decades, we are a passionate bunch of individuals who strongly believe in customer centric approach.

**20+** Years of Experience

**2500+** Installations worldwide

**30+** Automation Products

# Clientele

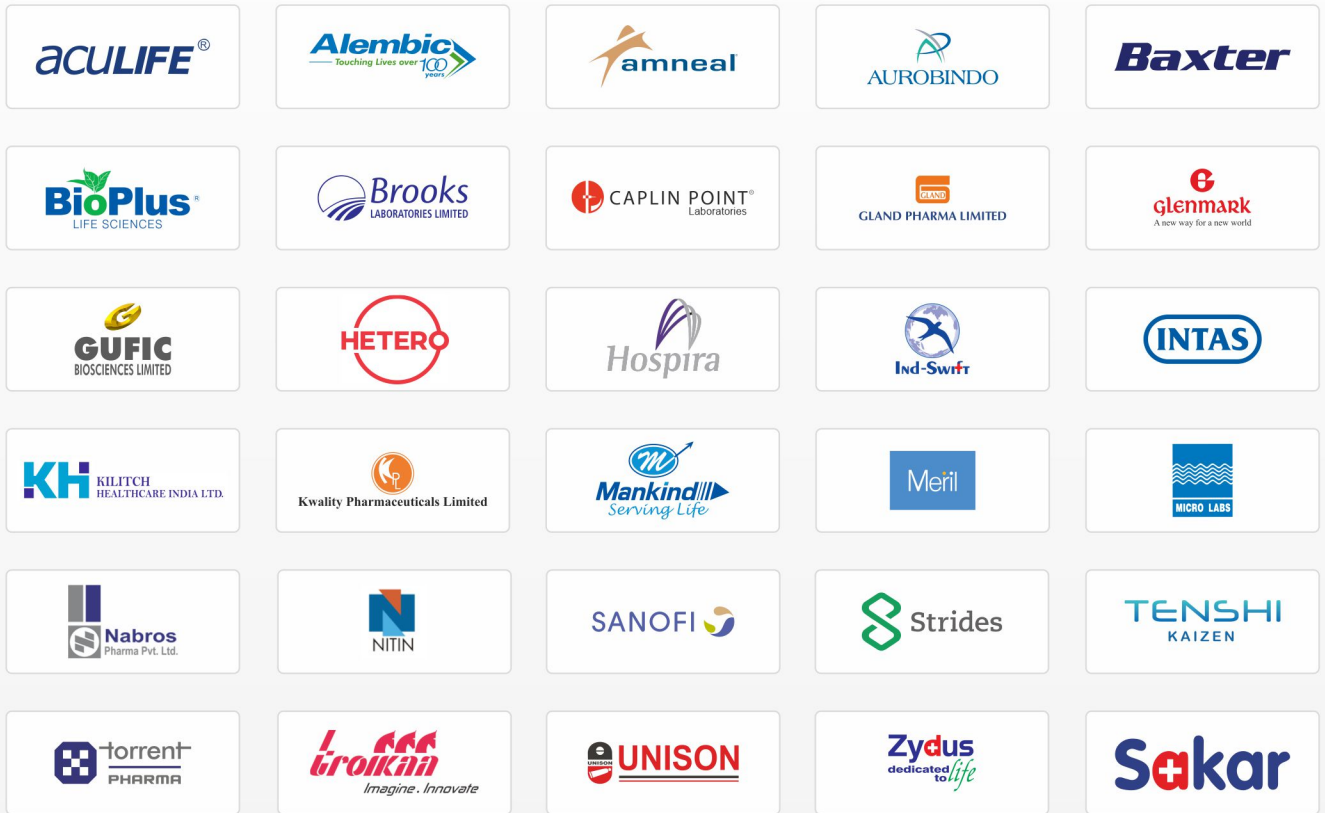

and many more..



Corporate office  
Shubham Automation Pvt Ltd  
Plot# 40/10, Phase-1, GIDC-Vatva,  
Ahmedabad-382 445, India.

Tel: +91 79 40081156 | +91 75 75801301 / 2  
sales@shubhamautomation.co.in  
www.shubhamautomation.co.in