

# CheckWeigher



## Inventive Accuracy Assured

Ever encountered the difficulties of underweight packaged products, or the horror of finding out that packaging just does not contain the product. One of the surest ways of being sure of the weight is the Check Weigh machine. It safeguards your product from accuracy pains as well as your brand from credibility losses.

## Delivering Business Assurance

Shubham Technologies with its aggressive innovation driven research presents to you the Check Weigher Machine which takes away all your packaging weight woes to the last gram. Our automatic Checkweigher comes with state-of-the-art software technology that not only combines the speed and accuracy but also gives out in-depth analysis which can help solve challenges at the shop-floor level.

Our special link grid conveyor infeed belt can be customized to a desired speed and also has an inbuilt indexer which builds a sufficient gap between products for optimal distance and weight. Any out-of-tolerance product to the last gram gets collected in the reject bin which too has special sensors that verify the entry of the product.

Shubham's Checkweigher confirms to all Global standards and industry norms.

---

## Unique Features of Checkweigher

- 3S: Sharp, Sturdy & Simple
- Best in Performance & Price
- Large colour touch screen for ease of use & view
- Fluid Damped / EMFR / Beam Point weighing technology selection based on application
- Rejection selection through air blow /pusher / diverter / flapper / pull according to machine speed and products, shape and size
- Dynamic auto set point facility for any product
- Underweight / Overweight, double product rejection
- Tri-Colour Led tower light for operational overview
- Compact size requires minimum spaces on the production floor
- Smoothly driven conveyor gives better performance of machine
- Selection of various belts according to different products shape and size

## Unique Features of Central Controller

- Industrial PC for central processing
- Complete 21 CFR part 11 Compliance
- Audit Trail Report to record each and every instance
- Alarm History Report with time stamp.
- Digital Signature Verification to prohibit unauthorized access
- User Management with different access rights allocation facility
- Group Management Facility
- Different Reports like Total Production Report , Total Pass Report , Total Rejection Report , Batch Detail Report & Batch Summary Report
- Different Alarms like Low air machine stop / Emergency Stop / Consecutive fail stop / Continuous Sensor on (Sensor Jam)
- Product Analysis by 4 Weight Zone Classification
- Report printing and USB storage facility
- Online Weight & Zone Distribution graph display
- Data Backup and Restore facilities
- Various screens & Menus protected with multi level password security system
- Specimen Selection Library for unlimited products

### Specification

### SAS-WC-1000 IPC

Weight Range	Up to 1000 grams
Throughput (Weighing /Minute) (*1)	Max 100 to 120
Accuracy (*2)	From +/- 300 mg
Display Resolution	0.1g
Operating Height in mm (*3)	700-850
Weighing Technology	Fluid Damped Load Cell
Environmental Degree Protection	Ip65
MOC	SS304/AL
Air Supply	6 Kg/sq cm
Power Supply	230 VAC , Single Phase , 50/60 Hz

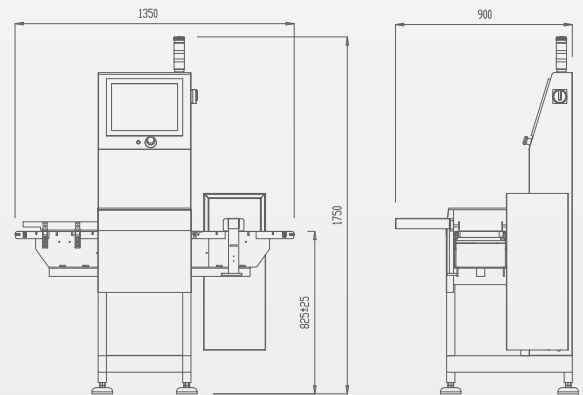

All Dimension are in mm only

Note that all dimensions of the machine are vary according to final object's shape & size.  
Company can change any dimension or design of the machine without any concern or notice.



Corporate office  
Shubham Automation Pvt Ltd  
Block B - 201 / 202, Dev Aditya Arcade,  
Nr Baghban Party Plot, Thaltej,  
Ahmedabad-380054. India.

Tel: +91 79 40321041 | +91 7575801301  
sales@shubhamautomation.co.in  
www.shubhamautomation.co.in