

EZPCR-M-PL

Shrinking your pains

If curves and odd and end scanning is a pain for you or large to very large shipments need personal attention, then EZPCR-M-PL is your buddy in distress. This wireless scanner proves to be a boon in all industrial applications. Equipped with an all in one industrial PC with a 15 inch touch monitor, EZPCR-M- PL is easy to use, view and secure all your scanning operations.

To be compliant with 21 CFR Part 11, EZPCR-M-PL is the perfect accompaniment. It can be integrated with TTO type printer to print parent label for pallet with aggregation. EZPCR-M-PL can be a stand-alone unit to integrate with Smart Tracker as well as third party Track & Trace solutions. So, get handy with your time and worries and invest into EZPCR-M-PL.



Simplicity of Design

Simple screen for an effective scanning of the product from the parent-child cycle.



Hand-held Convenience

Simple printing done with the effective hand-held scanner making the entire process convenient.

Unique Features

- SS 304 made movable Operator console for ease of handling process
- Easily integrates & Works best with Smart Tracker as well as any Track & Trace solution
- Wireless Scanner for shipper scanning purpose
- 21 CFR Part 11 Compliance
- All in one Industrial PC with 15 inch touch monitor for ease of view and secure operation
- Integration with TTO type printer to print Parent label for Pallet with Aggregation
- Easily integrates & Works best with Our T & T software- SMART TRACKER as well as any Third party software

Technical Details

Scan Station System

Cabinet Housing	Made from SS 304
Display	15.6 inch Color display
Printer	TTO type Printer
Handheld Scanner	Capable to read 1D / 2D code
Machine Dimension	550 (L) X 770 (W) X 1320 (H) mm
Supply	230 VAC

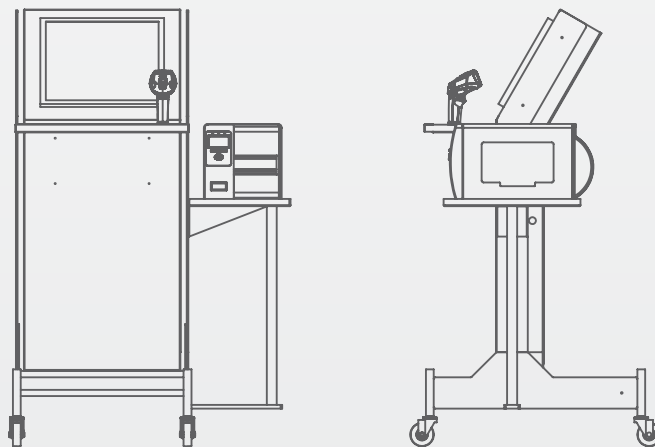

Note that all dimensions of the machine are vary according to final object's shape & size.
Company can change any dimension or design of the machine without any concern or notice.



Corporate office
Shubham Automation Pvt Ltd
Plot# 40/10, Phase-1, GIDC-Vatva,
Ahmedabad-382 445, India.

Tel: +91 79 40081156 | +91 75 75801301 / 2
sales@shubhamautomation.co.in
www.shubhamautomation.co.in