

# PNS - VAC

## Pioneering Novel Solutions

For any industry be it pharma, FMCG or Chemical industry, Unfolded Carton labelling can be a difficult of worrisome process. Not any more, with Shubham Automation's PNS FC. Its housing cabinet is made from SS - 304 making it sturdy and class at the same time. PNS FC is an offline product and can be your end of the line comfort.

Offering printing with Laser coding as well as the standard TIJ and TTO, PNS FC also comes with high resolution GigE vision hardware with special designed illumination for a strong vision support. So, with unfolded cartons on any size or dimension, Shubham Automation's PNS FC is your one stop answer.



### The Complete Package

Its compact design conveniently placing the printer and camera sections housed in a steel cabinet makes for a smooth operations leading to the pusher for effective rejections.



### Strong, Sturdy, Effective

Check out the unique conveyors with hole for a strong and effective vacuum hold.

The top mounting makes for all size loading as well as effective printing and scanning.

## Unique Features

- Easily integrates with any cartonator / check weigher / packing conveyor
- Vacuum type conveying technology gives accurate and jerk free movements of cartons
- Single mounting for precise position of the Printer & Vision Systems
- Equipped with High Resolution Camera and Megapixel Lens for precise decoding of Data Matrix and Over coding
- Centralised control of Printer and vision system for message security
- Multiple camera support through EZ-PNS software
- Multiple printing technology support like TIJ, CIJ, Laser
- Speed of Printing & Inspection up to 120 carton per minute
- Highly Efficient vision tools to perform on any type & any colour carton surface
- User Friendly Operating Software with 21 CFR PART 11 Compliance
- Large colour display for ease of use and view
- Sensor less Encoder based rejection logic
- Easily integrates & works best with Our T & T software- SMART TRACKER as well as any Third party software
- Fully Safe & Compact design

## Technical Details

## Scan Station System

Cabinet Housing	Made from SS 304
Display	15.6 inch Color Touch screen Industrial display
Printer	TIJ / CIJ / Laser
Camera	High Resolution GigE Vision Hardware with specially designed illumination
Vision Tools	OCR/OCV, Datamatrix, Pharmacode, 1 D Barcode, Pattern matching
Conveying Mechanism	Vacuum Type PVC belt Conveyor
Machine Dimensions in mm	1200 (L) x 900 (W) x 2050 (H)
Speed in PPM (Product Per Minute)	120 PPM
Product suitability	folded Carton with printing on side or top position
Supply	230 VAC

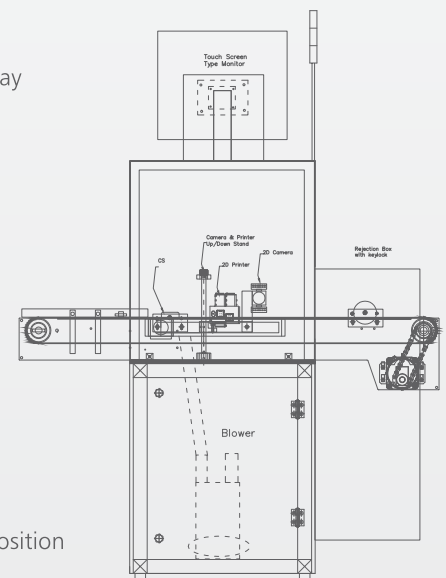

Note that all dimensions of the machine are vary according to final object's shape & size.  
Company can change any dimension or design of the machine without any concern or notice.



Corporate office  
Shubham Automation Pvt Ltd  
Plot# 40/10, Phase-1, GIDC-Vatva,  
Ahmedabad-382 445, India.

Tel: +91 79 40081156 | +91 75 75801301 / 2  
sales@shubhamautomation.co.in  
www.shubhamautomation.co.in